

# ***EAGLE***

## **DRUM INVERTERS**

---

### **Hydraulic Drum Dumpers**

- For unloading drums, barrels, and various other containers

The Eagle Drum Inverter is a versatile material handling machine built for rugged, heavy duty or light industrial use. It unloads and assortment of containers of all sizes and weights.

Customized container dumpers are available with options such as enclosed units for dusty materials, wide body drums, stands to change the discharge height, and custom discharge chutes. Push button controls permit stopping the unit at any point.

Standard features include:

- Lift Capacity: 1,200 lbs.
- Drive: 1 hp, 240/460, 3 ph, 60 hz
- Base Dimension: 40" x 36"
- Operation: Self contained, hydraulically activated design
- Mounts Permanently to Floor
- Maximum Container Size: 55 gallon drum

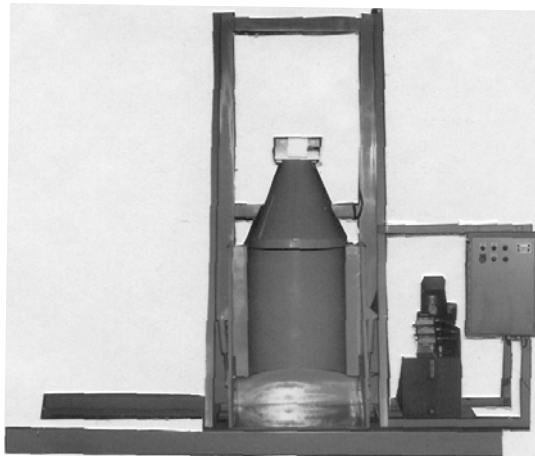

# PRODUCT OVERVIEW

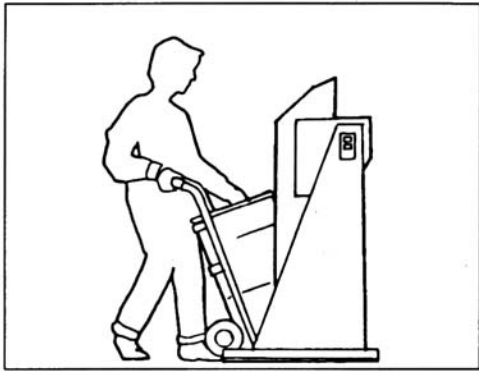

The Eagle Drum Inverter is designed with a floor level loading tilt bucket that allows easy, no lift loading of full drums of material. Operator controls are conveniently located on the upper portion of the Inverter framework.

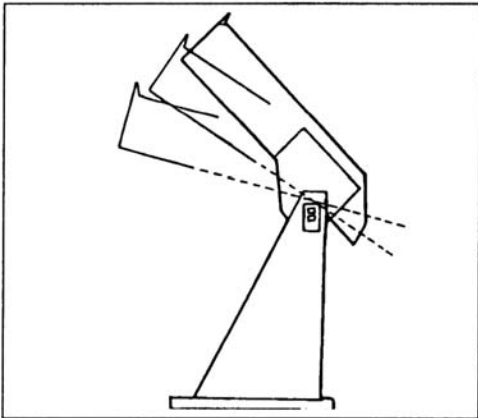

During operation the bucket of the Inverter lifts and rotates the drum to a full 45 degrees to insure full discharge of material from the drum container. For greater control of the material discharge rate, the bucket may be stopped safely at any angle desired during the dump cycle.

Along with the standard Drum Inverter described here, Eagle offers fully enclosed Inverter buckets and Inverters that lift and rotate drums to a full 180 degrees.

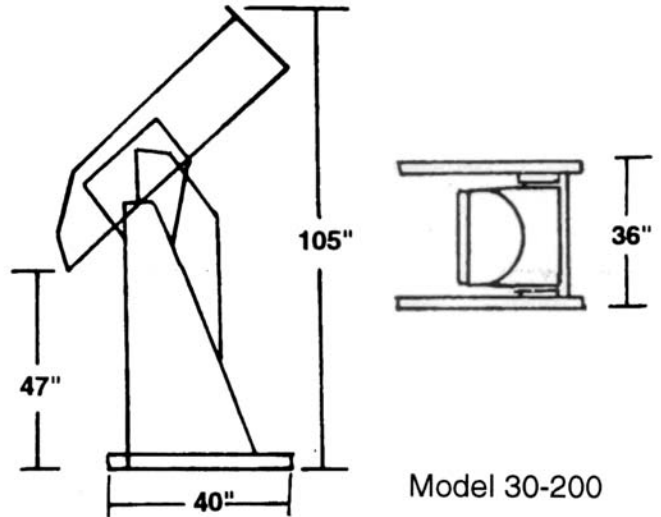

Model 30-200

## DRUM INVERTER FEATURES:

Capacity: 1200 lbs.

Base Frame: Welded heavy gauge carbon steel with base anchor holes pre-drilled.

Lift Mechanism: Single hydraulic cylinder

Electrics: 1HP, 240/460 V, 3ph, 60hz motor

Finish: Vista Gray epoxy

Options: Customer specified dump height  
Stainless steel material contact surfaces.  
Enclosed Inverter bucket.  
180 degree rotation.  
Custom designs.

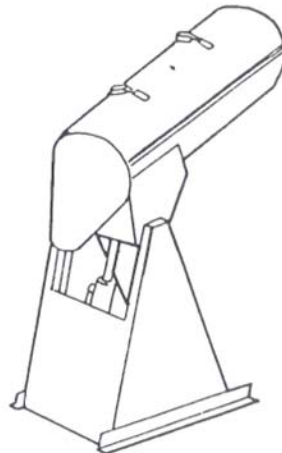

Model 30-211

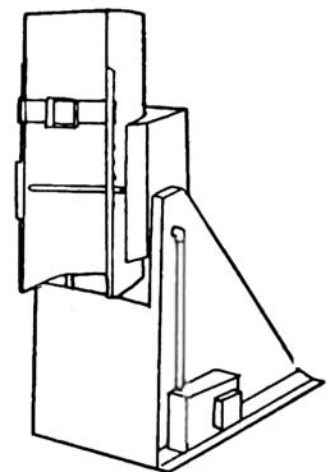

Model 30-205

The Eagle Group, Ltd.  
8384 W. Peck Road  
Greenville, MI 48838

Phone: (616) 754-7777  
Fax: (616) 754-1555  
e-mail: sales@eaglegroup Ltd.com  
Web Page: www.eaglegroup Ltd.com