

# EAGLE

## BULK BAG UNLOADER

Eagle Modular Unloaders are designed to meet specific process requirements. A complete variety of Unloaders is available to suit all materials and bag types.



Basic Version

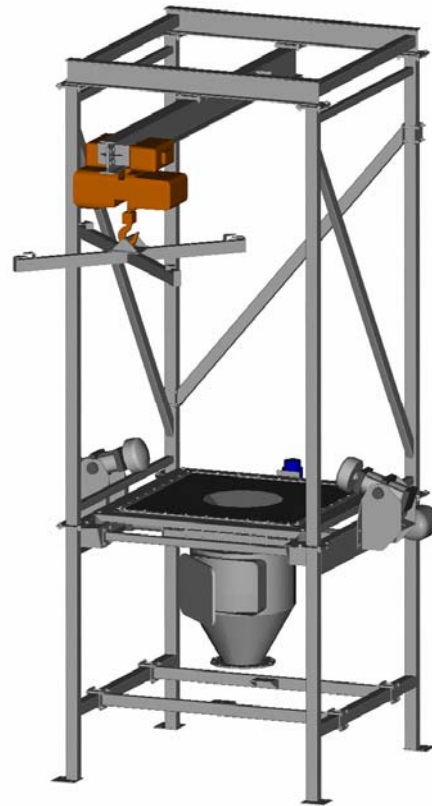

Support Frame With  
Lifting Hoist Attachment

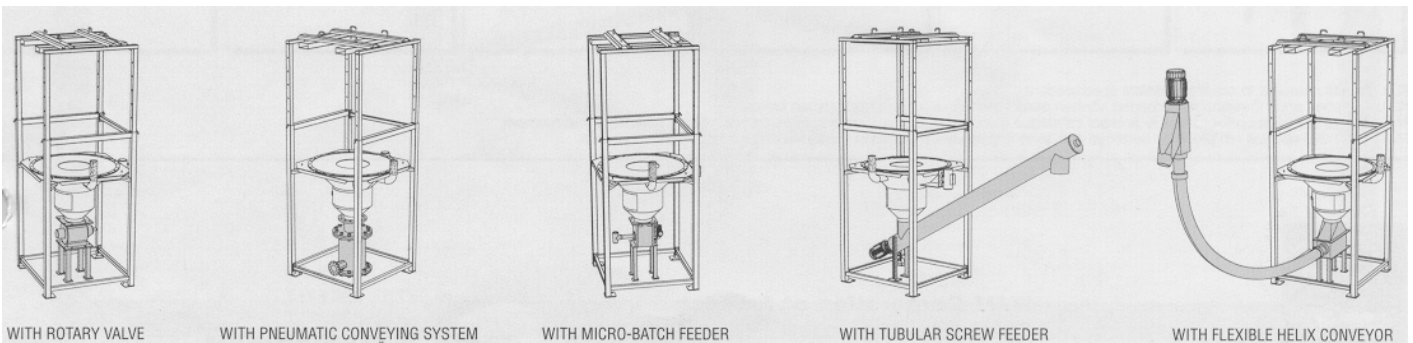

WITH ROTARY VALVE

WITH PNEUMATIC CONVEYING SYSTEM

WITH MICRO-BATCH FEEDER

WITH TUBULAR SCREW FEEDER

WITH FLEXIBLE HELIX CONVEYOR

**THE EAGLE GROUP LTD.**

**Bulk Bag Unloaders are available with:** (1) pneumatic vibrator and bag thumper, (2) flow control valve, (3) hoist attachment, (4) bag cutting system, (5) self lifting support frame, (6) fork truck attachment frame, (7) inside bag liner re-tainer, (8) dust control; including dust collector if needed, (9) glove box for toxic materials, (10) inflatable dust seal, (11) hoppers equipped with rotary air valves, vacuum conveying systems, micro batch feeders, tubular screw feeders, and flexible helix conveyors.

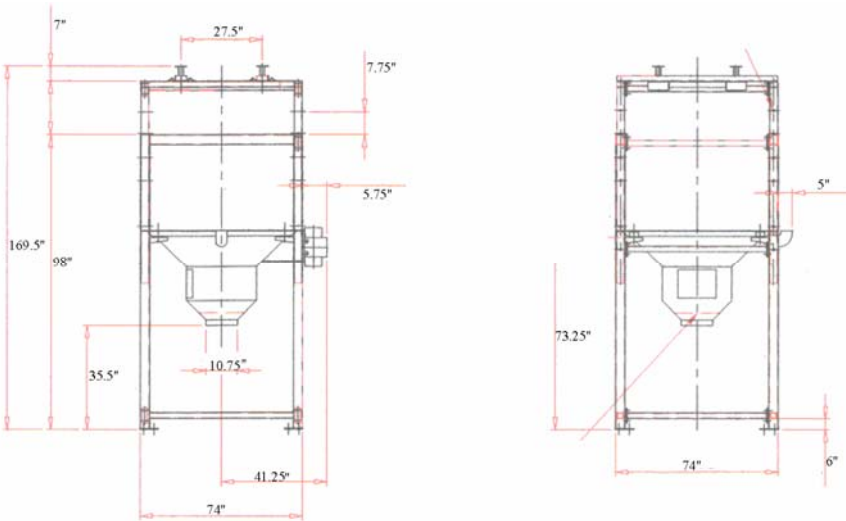

Pneumatic Self-Lifting Support Frame

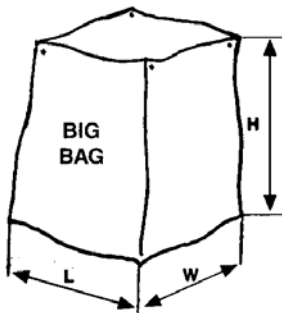

MAX Dimensions of Big Bag		
L	W	H
40"	40"	74"
40"	40"	86"



Hopper for Toxic Products Glove Box

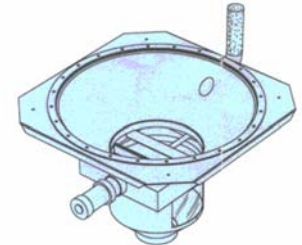

Hopper With Flow Control Valve

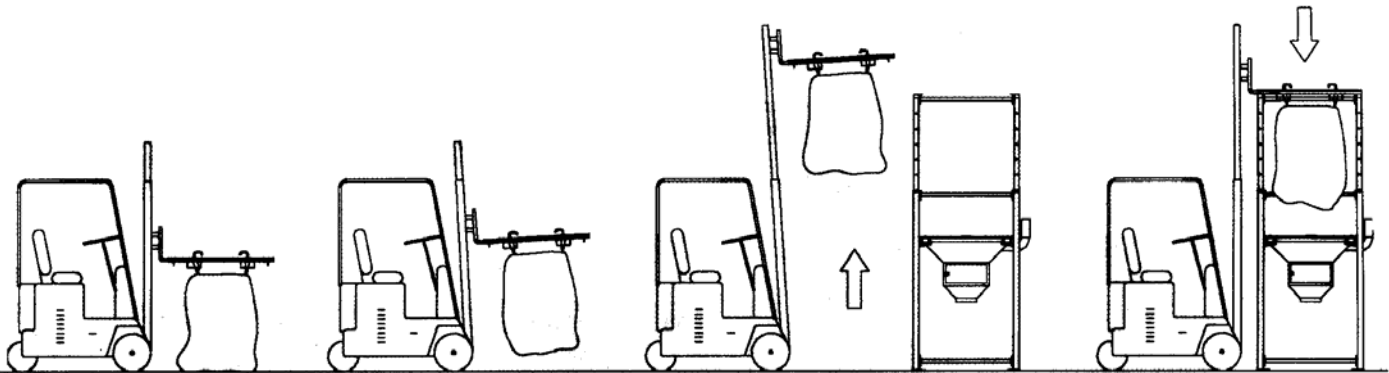

The Eagle Group, Ltd.  
8384 W. Peck Road  
Greenville, MI 48838

Phone: (616) 754-7777  
Fax: (616) 754-1555  
E-Mail: sales@eaglegroup Ltd.com  
Web Page: www.eaglegroup Ltd.com